

AndonWIRELESS / Andon product

AndonWirelessBOX 2-Button 921 MHz



Part No.: 860.000.17



MECHANICAL DATA	
Length	103 mm
Width	66 mm
Height	35 mm
Materials	PC PC/ABS
Housing colour	Black Grey
Protection category	IP30
Type of fixing	Base mounting Wall mounting
Working temperature minimum	0°C
Working temperature maximum	+40°C
Weight with packaging	428 g
Product weight	273 g

ELECTRICAL DATA	
Operating voltage	115-230V
Operating voltage type	AC
Operating voltage frequency	50Hz at 230V 60Hz at 115V
Operating voltage tolerance	+/- 10%
Rated operational voltage	230 VAC
Rated operational current	500 mA
Protection class	Protection class 2
Pollution degree	2
Overvoltage category	II
Isolation voltage	Ui = 250V; Uimp = 2.500V
Radio range max.	200 m
Radio transmission power	10 dBm at 50 Ohm
Radio frequency min/max	921.000 MHz 922.000 MHz
Radio channels	6
connectivity	USB

APPROVAL DATA	
Conforms with CE	No
WEEE	Yes
Conforms with RED directive	No
Conforms with CCC	No
Conforms with UL	cULus I.T.E. E503964

! For additional installation and mounting information, refer to the appropriate user guide at www.werma.com. This printed copy is for information only and is subject to alteration.

AndonWIRELESS / Andon product

AndonWirelessBOX 2-Button 921 MHz

Conforms with FCC	Yes
Conforms with IC	Yes
EAC certificate available	No
Conforms with UKCA (Importer)	No
Conforms with AS-I	No
Conforms with DNV	No
Conforms with RoHS CN	10 years
Conforms with VdS	No

DRAWING

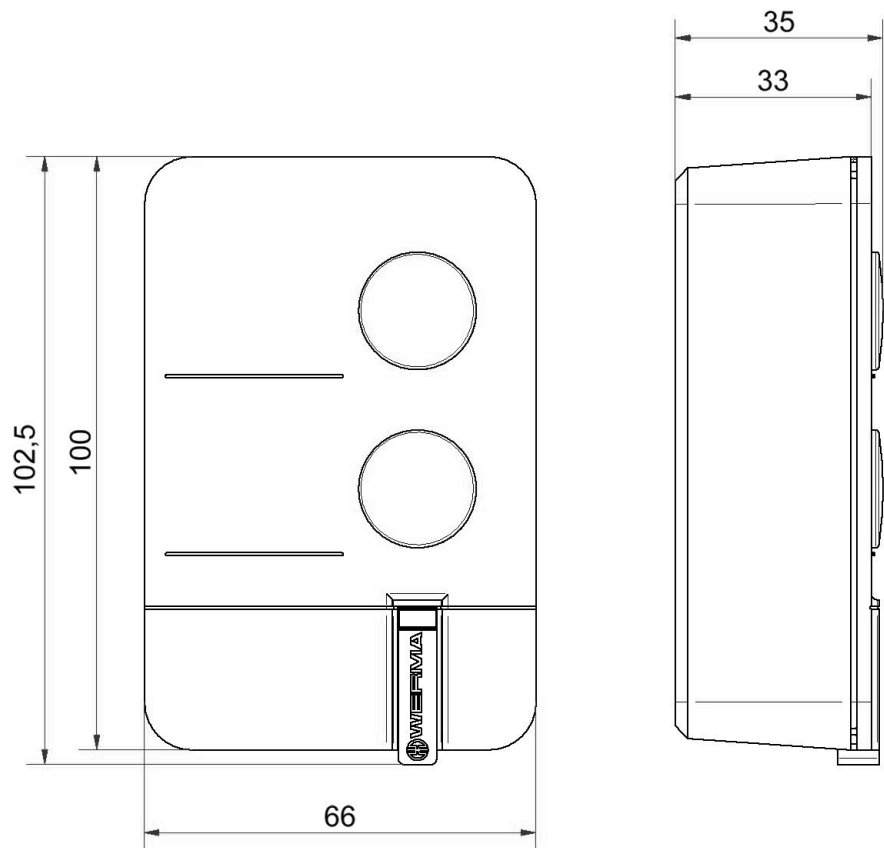

! For additional installation and mounting information, refer to the appropriate user guide at www.werma.com. This printed copy is for information only and is subject to alteration.