

- (D) Anschluss **ausschließlich** durch ausgebildete Elektro-Fachkräfte.
- (GB) Electrical connection is to be made by trained electrical specialists **only**.
- (F) Le branchement doit **uniquement** être effectué par des professionnels.
- (I) Il collegamento deve essere eseguito **solo** da elettricisti specializzati.
- (E) La conexión **sólo** debe ser realizada por electricistas debidamente formados.
- (PT) A ligação deve ser feita **exclusivamente** por profissional elétrico especializado.
- (NL) De aansluiting mag **enkel** gebeuren door erkende vakmensen.
- (CZ) Připojení smí **provádět** pouze kvalifikovaný personál.
- (PL) Podłączenie **wyłącznie** przez specjalistów-elektryków.
- (FI) Liittäminen kuuluu **ainoastaan** koulutettujen sähköalan ammattilaisten tehtäviin.
- (RUS) Подключение проводится только специа-листом-электриком.
- (TR) Bağlantı **sadece** eğitimli elektrik teknisyenleri tarafından yapılmalıdır.
- (CN) 布线需由专业电工执行

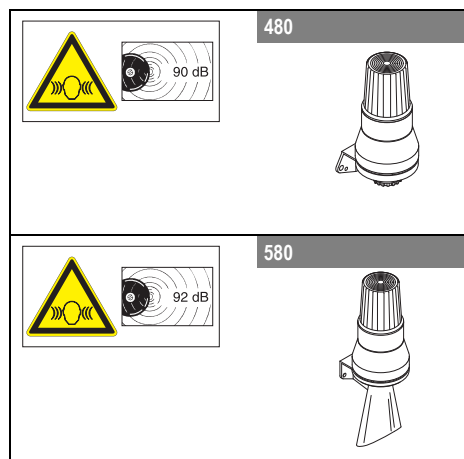

480 x52 54	90 dB, 12 V=, 610 mA
480 x52 55	90 dB, 24 V=, 320 mA
480 x52 66	90 dB, 48 V=, 170 mA
480 x52 68	90 dB, 230 V~, 50 mA
580 x52 54	92 dB, 12 V=, 610 mA
580 x52 55	92 dB, 24 V=, 320 mA
580 x52 65	92 dB, 24 V~, 320 mA
580 x52 56	92 dB, 48 V=, 220 mA
580 x52 67	92 dB, 115 V~, 75 mA
580 x52 68	92 dB, 230 V~, 50 mA

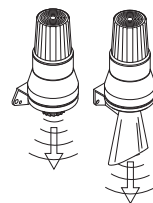
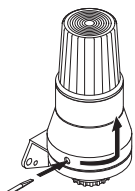

BA15 d, ≤ 7 W

955 015 34	12 V=
955 015 35	24 V=
955 015 36	48 V=
955 015 37	115 V=
955 015 38	230 V=



1

1a - 480
1b - 580

1a

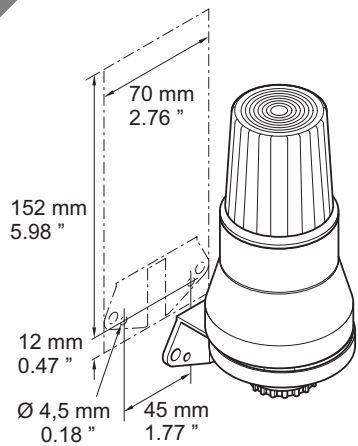

1b

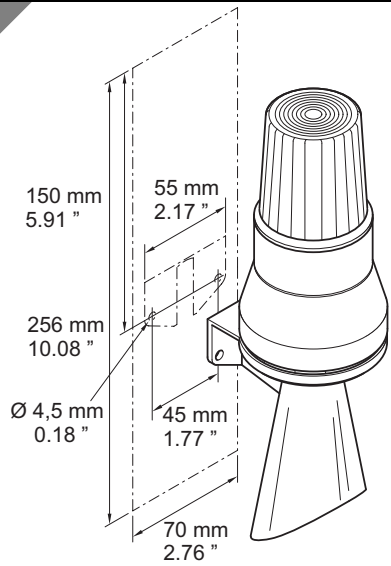

2

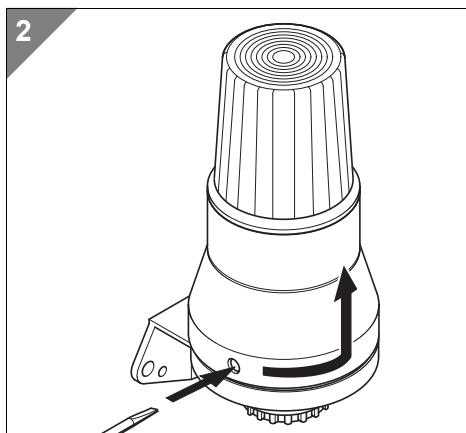

3

3a - 480
3b - 580

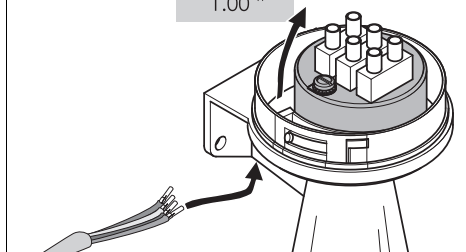
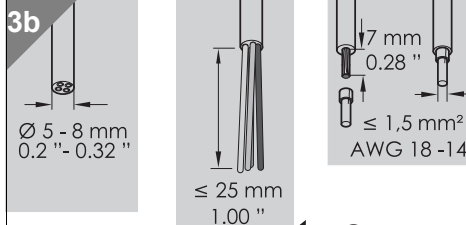
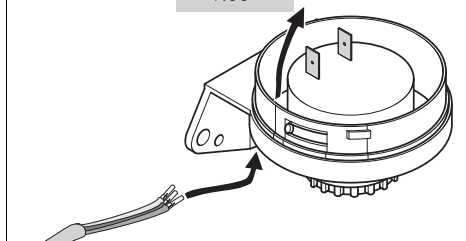
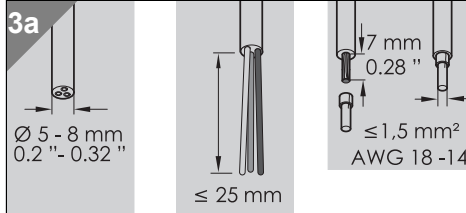

4

4a - 480
4b - 580

4a

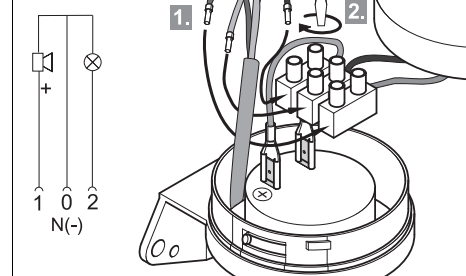

4b

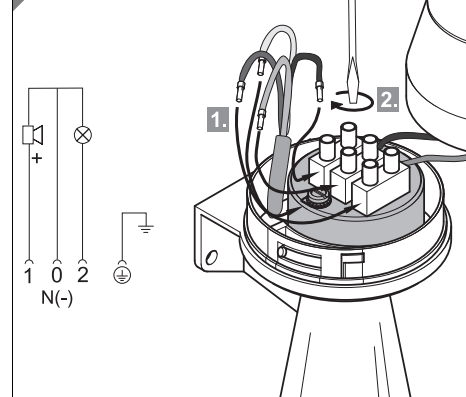

5

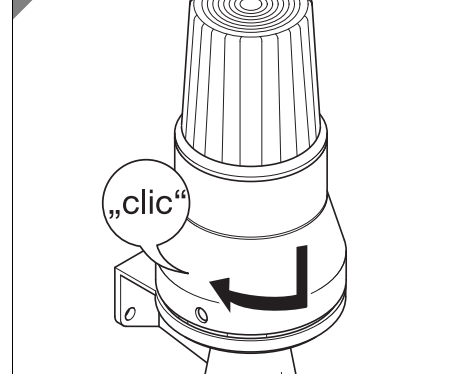

6

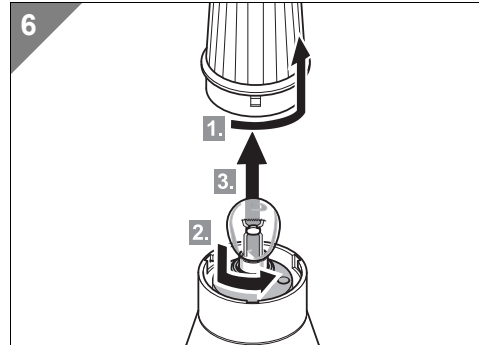

310.480.001.0814

© D

WERMA
SIGNALTECHNIK