

Heavy-Duty / Flash/Multi-Tone Sounder 442

**Flash/Sounder WM 42 tne 18-30VDC GY/YE**

Part No.: 442.130.55

**MECHANICAL DATA**

Length	211 mm
Width	168 mm
Height	155 mm
Materials	PC/ABS
Dome colour	Yellow
Housing colour	Grey
Protection category	IP66
Connection	Screw terminals
cross-sectional area minimum	0,25mm <sup>2</sup> / 24AWG
cross-sectional area maximum	1,50mm <sup>2</sup> / 16AWG
Cable entry	Screwed cable gland
Cable entry minimum	d = 8 mm
Cable entry maximum	d = 12 mm
Tension relief	Present (conforms to VDI)
Type of fixing	Wall mounting
Service life optical	50,000 h maximum
Acoustic service life	5,000 h minimum
Working temperature minimum	-25°C
Working temperature maximum	+75°C
Weight with packaging	1988 g
Product weight	1773 g

**ELECTRICAL DATA**

Operating voltage	18-30V
Operating voltage type	DC
Operating voltage tolerance	+/- 0%
Rated operational voltage	24 VDC
Rated operational current	450 mA
Protection class	Protection class 2
Pollution degree	3

**OPTICAL DATA**

Light source	Xenon
Light colour	Yellow
Optical signal image	Flash
Flash frequency	2 Hz
Flash output	3.5 J
Blink frequency (Hz)	2 Hz



For additional installation and mounting information, refer to the appropriate user guide at [www.werma.com](http://www.werma.com). This printed copy is for information only and is subject to alteration.

Heavy-Duty / Flash/Multi-Tone Sounder 442

**Flash/Sounder WM 42 tne 18-30VDC GY/YE**

ACUSTICAL DATA	
Volume/dB(max) at 1m distance	120,0 dB dB(A)
Acoustic signal image	Multi-tone
Number of tones	42 tone

**DRAWING**

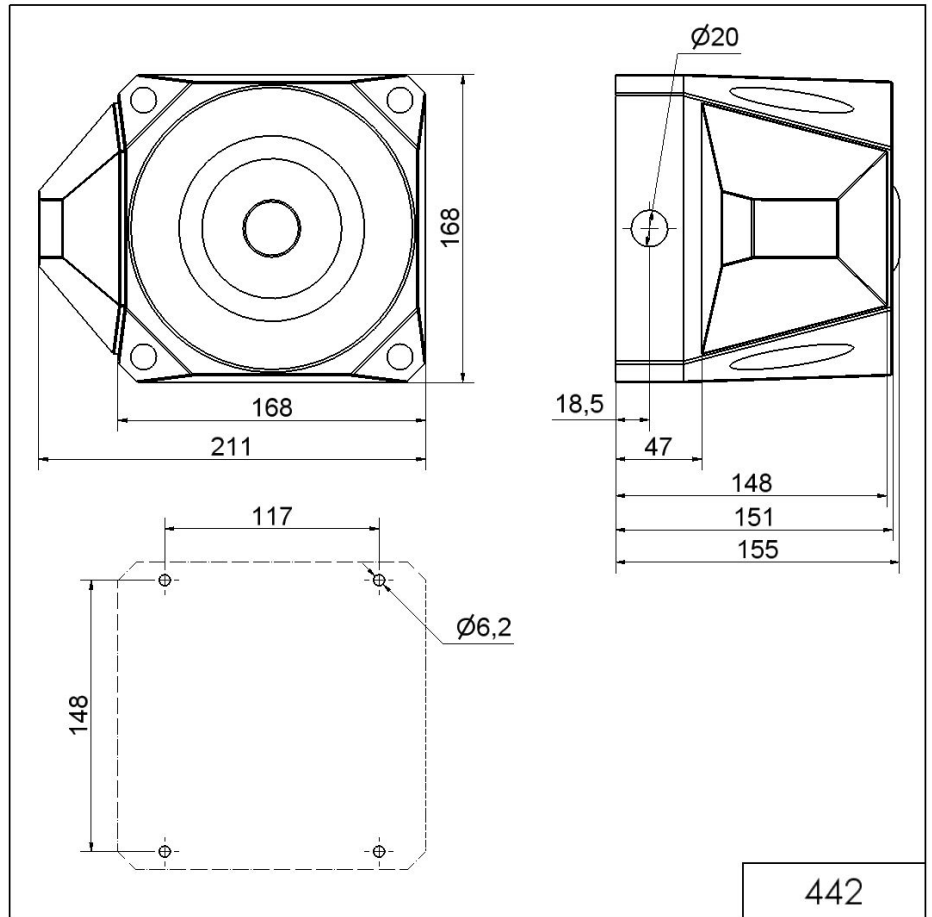

For additional installation and mounting information, refer to the appropriate user guide at [www.werma.com](http://www.werma.com). This printed copy is for information only and is subject to alteration.