

LED Siren WM 32 tne 115-230VAC YE



Part No.: 433.310.60

**MECHANICAL DATA**

Length	144 mm
Width	134 mm
Height	235 mm
Diameter	134 mm
Materials	PC PC/ABS
Dome colour	Yellow
Housing colour	Grey
Protection category	IP65
Connection	Screw terminals
cross-sectional area maximum	1,50mm ² / 16AWG
Cable entry	Membrane grommet
Cable entry minimum	d = 1 mm
Cable entry maximum	d = 13 mm
Tension relief	Present (conforms to VDI)
Type of fixing	Wall mounting
Service life optical	50,000 h maximum
Acoustic service life	5,000 h minimum
Working temperature minimum	-30°C
Working temperature maximum	+50°C
UL Type Rating	Type 12
Weight with packaging	663 g
Product weight	520 g

ELECTRICAL DATA

Operating voltage	115-230V
Operating voltage type	AC
Operating voltage type	50Hz at 230V 60Hz at 115V
Operating voltage tolerance	+/- 10%
Rated operational voltage	230 VAC
Rated operational current	125 mA
Rated inrush current	<10A
Protection class	Protection class 2
Pollution degree	3
Overvoltage category	II
Isolation voltage	Ui = 250V; Uimp = 2.500V

OPTICAL DATA

For additional installation and mounting information, refer to the appropriate user guide at www.werma.com. This printed copy is for information only and is subject to alteration.

LED Siren WM 32 tne 115-230VAC YE

Light source	LED
Light colour	Yellow
Optical signal image	Revolving

ACUSTICAL DATA

Volume/dB(max) at 1m distance	108,0 dB dB(A)
Acoustic signal image	Multi-tone
Number of tones	32 tone

DRAWING

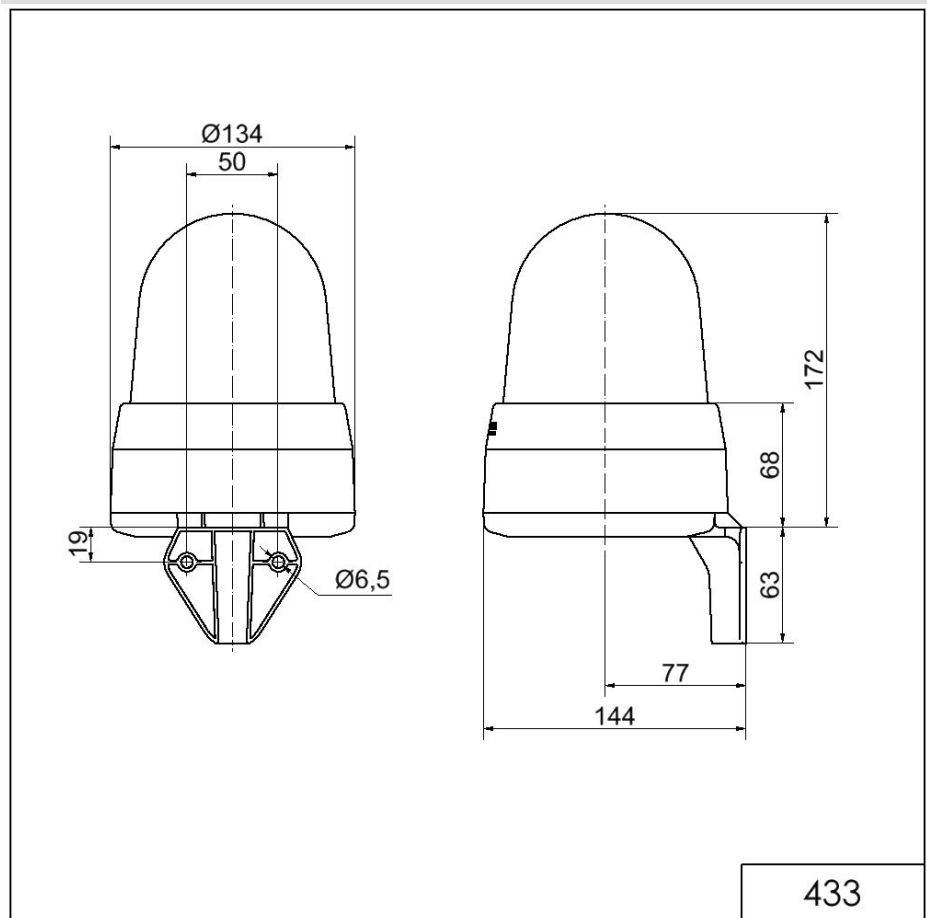

For additional installation and mounting information, refer to the appropriate user guide at www.werma.com. This printed copy is for information only and is subject to alteration.