

Completely pre-assembled Signal Towers / CleanSIGN
CleanSIGN WM Contin. tone 24VDC RD/GN/YE



Part No.:	695.200.55
Series:	CleanSIGN



MECHANICAL DATA	
Length	125 mm
Width	112 mm
Height	485 mm
Diameter	76 mm
Materials	PA
Dome colour	Clear
Housing colour	Black
Protection category	IP67 IP69K
Connection	Screw terminals
cross-sectional area maximum	1,50mm ² / 16AWG
Type of fixing	Wall mounting
Service life optical	50,000 h maximum
Acoustic service life	5,000 h minimum
Working temperature minimum	-30°C
Working temperature maximum	+50°C
Weight with packaging	596 g
Product weight	426 g

ELECTRICAL DATA	
Operating voltage	24V
Operating voltage type	DC
Operating voltage tolerance	+/- 10%
Rated operational voltage	24 VDC
Rated operational current	260 mA
Rated inrush current	280 mA
Protection class	Protection class 2
Pollution degree	3

OPTICAL DATA	
Light source	LED
Light colour	Green Red Yellow
Optical signal image	Permanent

ACUSTICAL DATA	
Volume/dB(max) at 1m distance	85,0 dB dB(A)
Acoustic signal image	Continuous tone
Audio frequency	2400 Hz



For additional installation and mounting information, refer to the appropriate user guide at www.werma.com. This printed copy is for information only and is subject to alteration.

Completely pre-assembled Signal Towers / CleanSIGN
CleanSIGN WM Contin. tone 24VDC RD/GN/YE

DRAWING

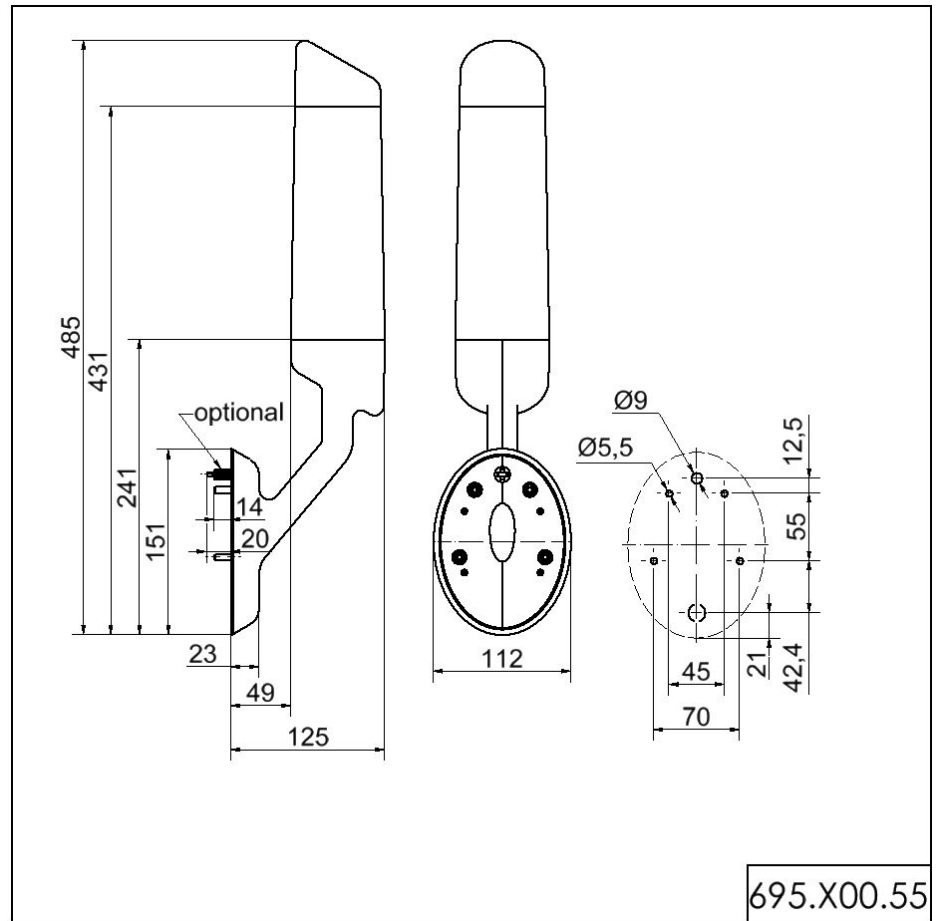

695.X00.55

! For additional installation and mounting information, refer to the appropriate user guide at www.werma.com. This printed copy is for information only and is subject to alteration.